

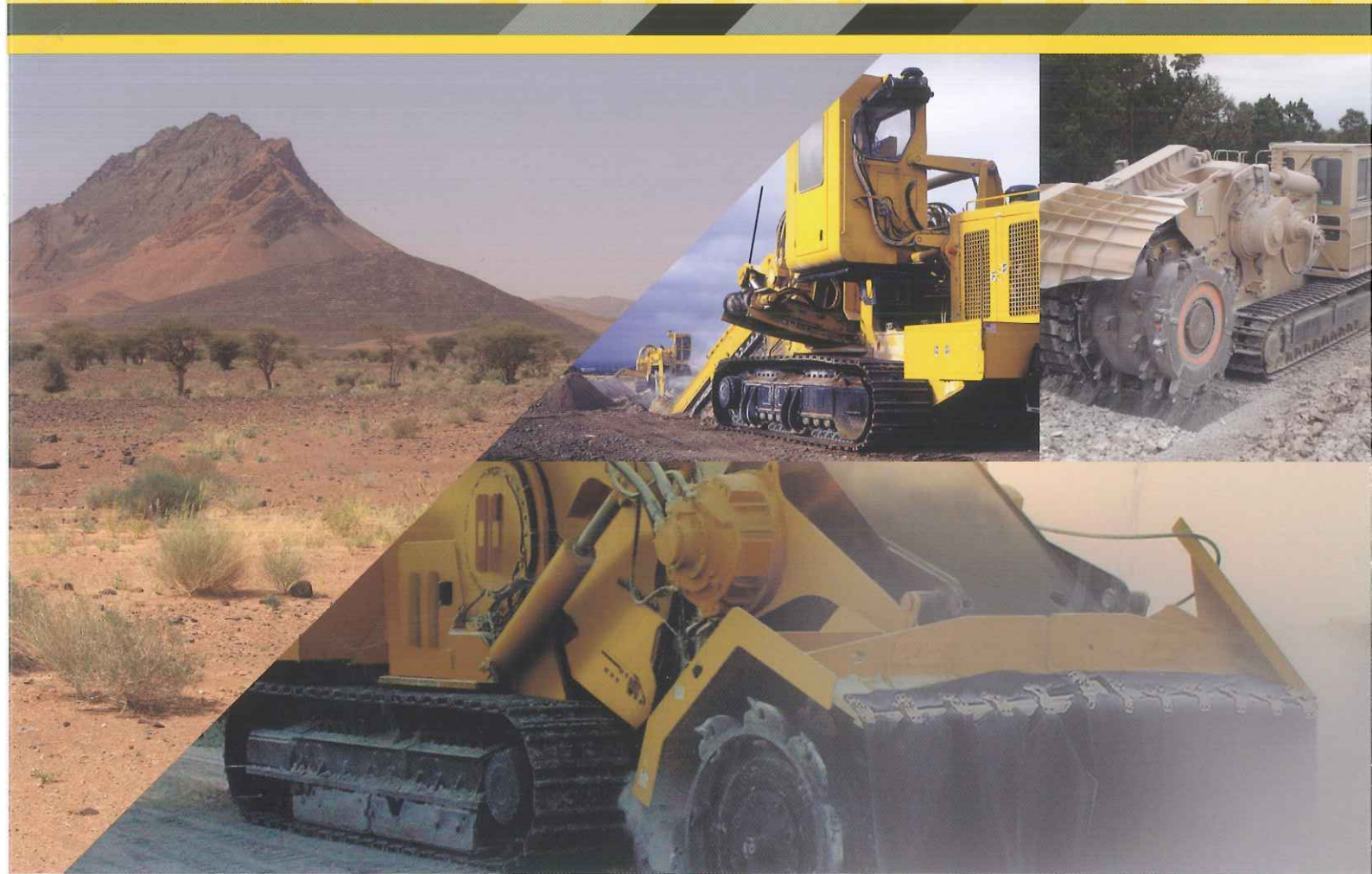

Trenching & Leveling Tools

38mm (1.18") / 30mm (1.5")

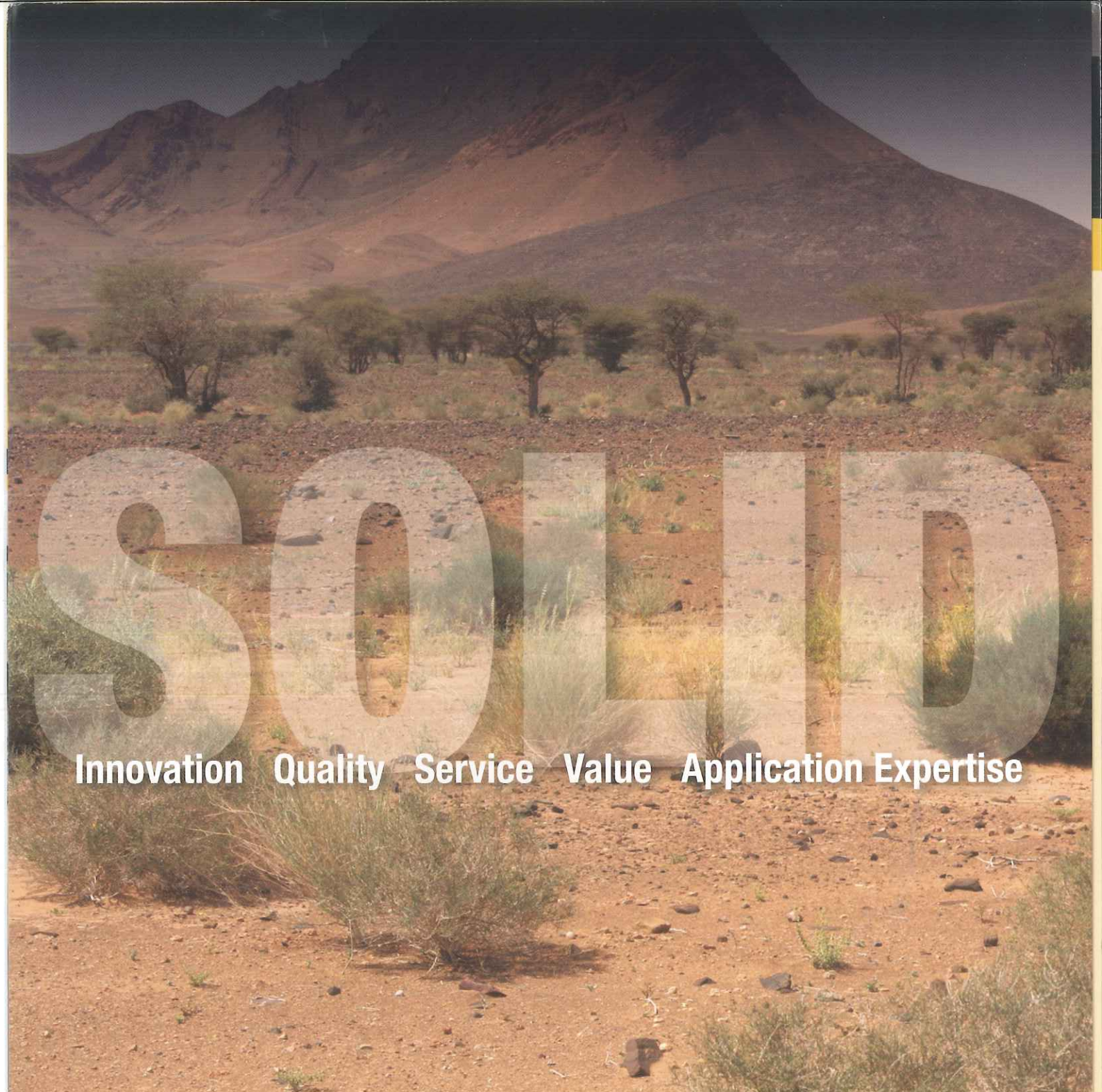



SOLID

Innovation Quality Service Value Application Expertise

The foundation for a successful trenching operation is built on rock-steady reliability and progress. Kennametal, the world's leading tooling and services provider, proudly introduces SOLID, our solution-focused platform that yields new levels of performance and productivity. SOLID-engineered tools deliver in the most challenging conditions.

**For unmatched quality, value, innovation, and application expertise,
make Kennametal your SOLID choice!**



Proven Reliability – Unparalleled Productivity.

No matter what your cutting conditions, equipment, or budget, we have just the tools you need!

GOLD

Our very best tools. Choose from this group when you want to save time and money long-term. Simply, these products – with their exceptionally durable bodies due to our proprietary hardness (**throughout the entire head**) process – deliver ultra-high performance over their lifetime versus any existing tools. That results in fewer teeth required, less downtime, and greatly reduced operating costs – thus helping you to become more productive and profitable! In addition, these tools incorporate our latest tip designs for maximum penetration and service. Plus, they have extra-wide collars for unmatched block protection.

UNIQUE BODY HARDNESS PROCESS PROVIDES HIGH-PERFORMANCE OUTPUT OVER LIFE OF TOOL
• EXTRA-WIDE COLLARS SAFEGUARD BLOCKS • LATEST TIP DESIGNS FOR ULTIMATE PENETRATION

SILVER

When your work calls for tools with *something beyond ordinary* performance, select from this series. Our unique carbide tip grades and designs, in conjunction with Kennametal's exceptional retention methods, yield superior results in even the most challenging applications!

EXTRA-WIDE COLLARS SAFEGUARD BLOCKS • LATEST TIP DESIGNS FOR ULTIMATE PENETRATION

BRONZE

Kennametal's Classic tools. Time-tested and proven in the field. For your everyday cutting requirements, no comparable products can provide the same efficiency!

LATEST TIP DESIGNS FOR ULTIMATE PENETRATION



GOLD

TSX Series
KR112 Retainer
1011979



TSXC Series
TR3 Retainer
4073124



TSX Series / TSCX Series

3.5 Gage

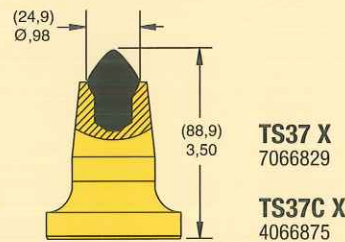
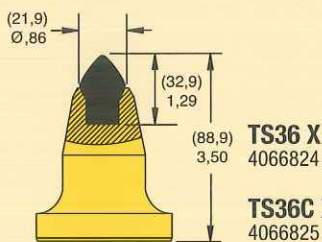
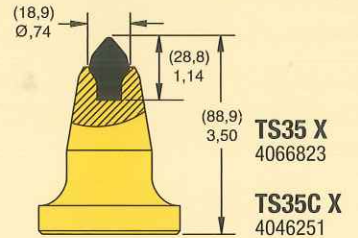
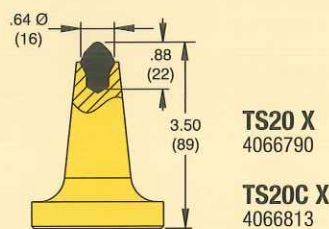
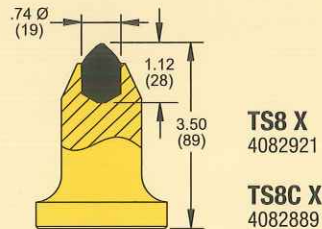
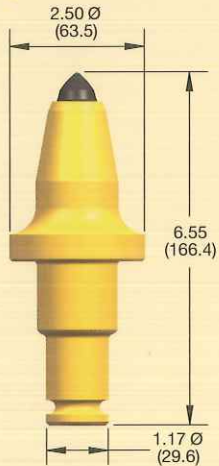

3.0 Gage

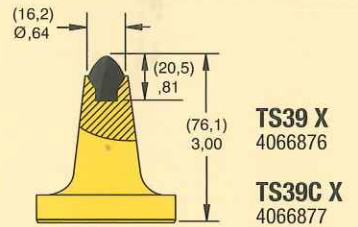
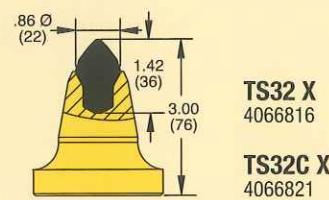
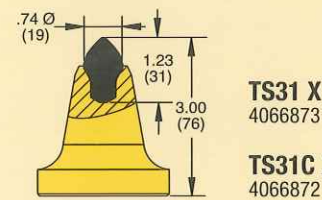
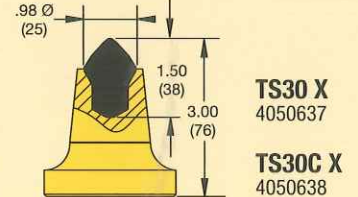
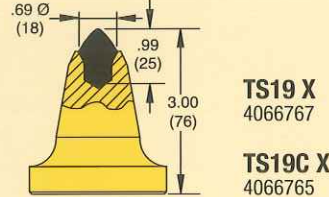
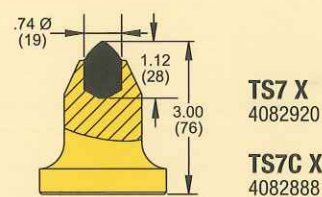

2.5 Gage

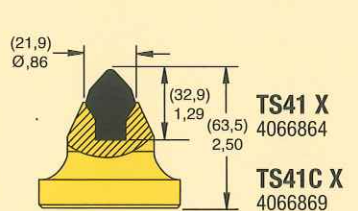
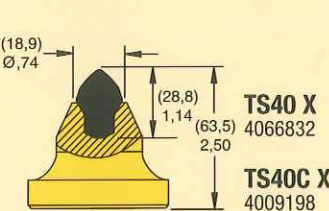
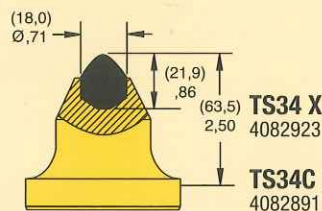
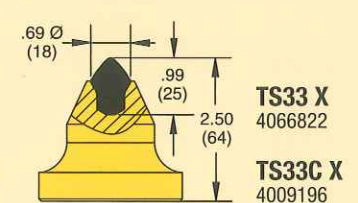
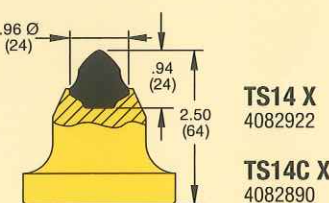
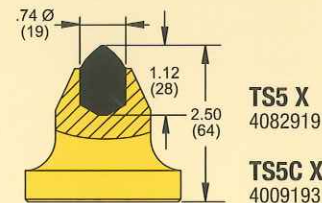
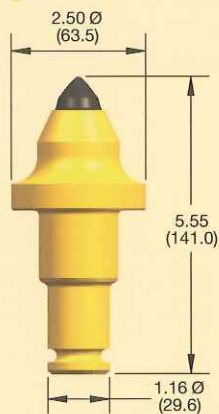

SILVER

TS Series
KR112 Retainer
1011979



TSC Series
TR3 Retainer
4073124



TS Series / TSC Series

3.5 Gage

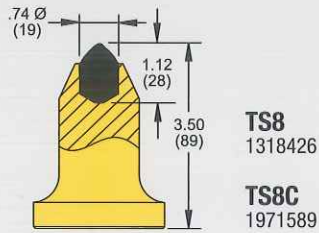

TS8C
1971589

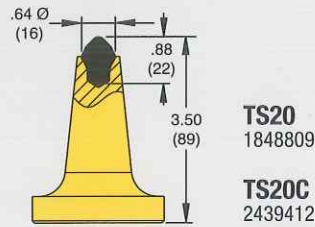

TS20C
2439412

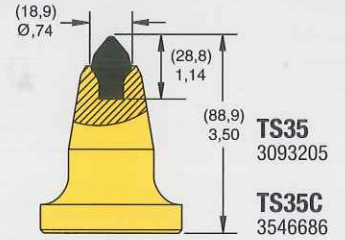

TS35C
3546686

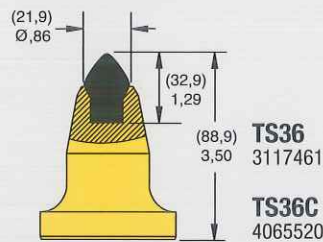

TS36C
4065520

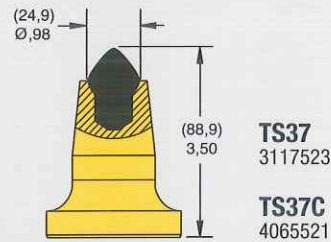

TS37C
4065521

3.0 Gage

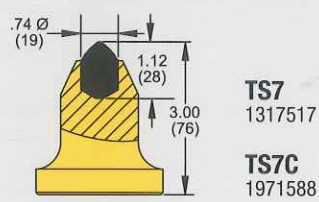

TS7C
1971588

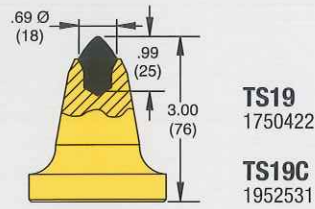

TS19C
1952531

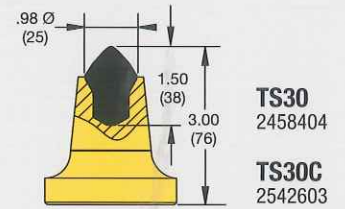

TS30C
2542603

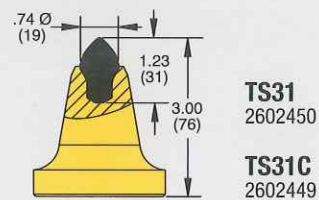

TS31C
2602449

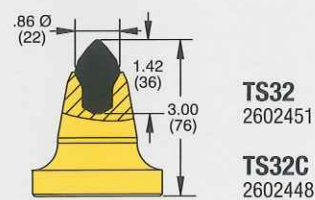

TS32C
2602448

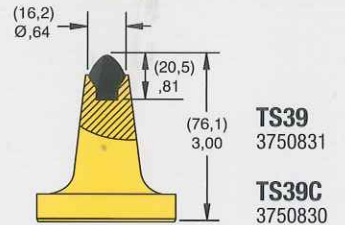

TS39C
3750830

2.5 Gage

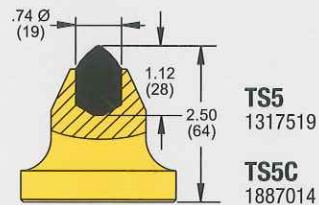
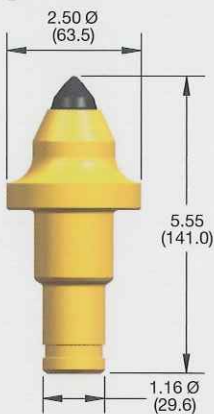

TS5C
1887014

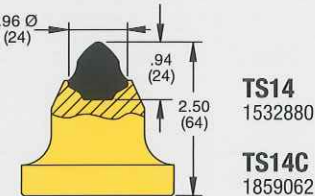

TS14C
1859062

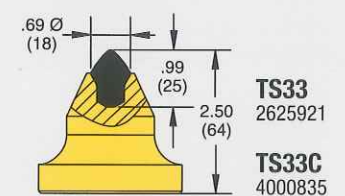

TS33C
4000835

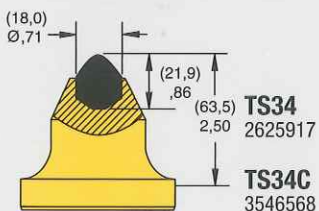

TS34C
3546568

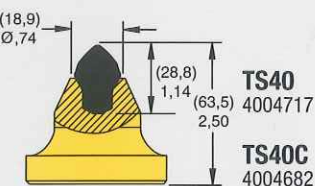

TS40C
4004682

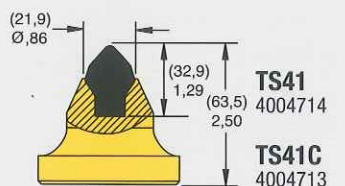

TS41C
4004713

BRONZE

TS Series
KR112 Retainer
1011979



C Series

Step Shanks

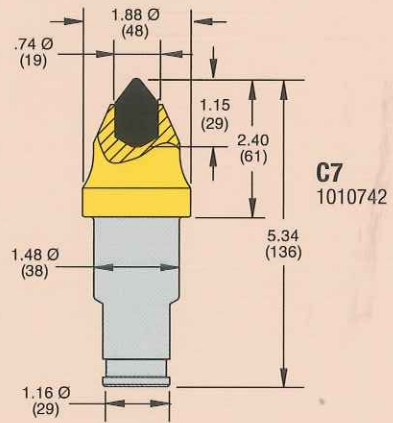
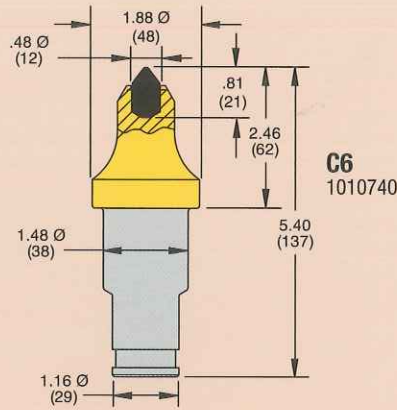
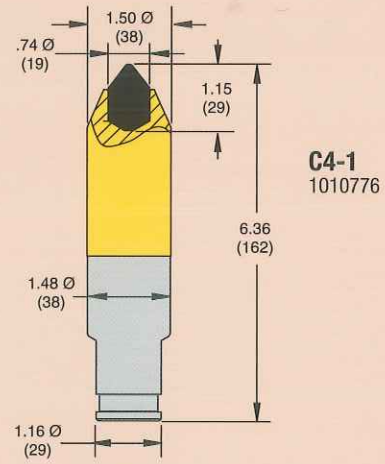
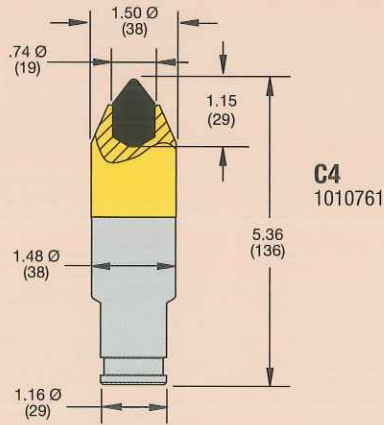

Made to Order

	Item (K-Groove)	Order Number	Item (C-Groove)	Order Number	New Item	Collar Dia. (mm)	Product Status	Recommended Application Chart / Conditions					Pieces per Box	Pieces per Pallet
								Soft Rock	Medium Rock	Hard Rock	Abrasive Rock	Laminated Rock		
TSX / TSCX Series	TS5 X	4082919	TS5C X	4009193	•	63.5	Made to Order	•	•	•			15	540
	TS7 X	4082920	TS7C X	4082888	•	63.5	Made to Order	•	•	•			14	504
	TS8 X	4082921	TS8C X	4082889	•	63.5	Made to Order	•	•				12	432
	TS14 X	4082922	TS14C X	4082890	•	63.5	Made to Order	•	•		•		15	540
	TS19 X	4066767	TS19C X	4066765	•	63.5	Made to Order	•	•		•		15	540
	TS20 X	4066790	TS20C X	4066813	•	63.5	Made to Order	•			•		14	504
	TS30 X	4050637	TS30C X	4050638	•	63.5	Made to Order	•	•	•	•	•	14	504
	TS31 X	4066873	TS31C X	4066872	•	63.5	Made to Order	•	•	•	•	•	15	540
	TS32 X	4066816	TS32C X	4066821	•	63.5	Made to Order	•	•	•	•	•	15	540
	TS33 X	4066822	TS33C X	4009196	•	63.5	Made to Order	•	•		•		15	540
	TS34 X	4082923	TS34C X	4082891	•	63.5	Made to Order	•	•				14	504
	TS35 X	4066823	TS35C X	4046251	•	63.5	Made to Order	•	•		•		12	432
	TS36 X	4066824	TS36C X	4066825	•	63.5	Made to Order	•	•		•		12	432
	TS37 X	7066829	TS37C X	4066875	•	63.5	Made to Order	•	•	•	•	•	12	432
	TS39 X	4066876	TS39C X	4066877	•	63.5	Made to Order	•	•		•	•	14	504
	TS40 X	4066832	TS40C X	4009198	•	63.5	Made to Order	•	•	•	•	•	15	540
TS41 X	4066864	TS41C X	4066869	•	63.5	Made to Order	•	•	•	•	•	15	540	
TS / TSC Series	TS5	1317519	TS5C	1887014		63.5	Stocked	•	•	•			15	540
	TS7	1317517	TS7C	1971588		63.5	Stocked	•	•	•			14	504
	TS8	1318426	TS8C	1971589		63.5	Stocked	•	•				12	432
	TS14	1532880	TS14C	1859062		63.5	Stocked	•	•		•		15	540
	TS19	1753623	TS19C	1952531		63.5	Stocked	•	•		•		15	540
	TS20	1848809	TS20C	2439412		63.5	Stocked	•			•		14	504
	TS30	2458404	TS30C	2542603		63.5	Stocked	•	•	•	•	•	14	504
	TS31	2602450	TS31C	2602449		63.5	Stocked	•	•	•	•	•	15	540
	TS32	2602451	TS32C	2602448		63.5	Stocked	•	•	•	•	•	15	540
	TS33	2625921	TS33C	4000835		63.5	Stocked	•	•		•		15	540
	TS34	2625917	TS34C	3546568		63.5	Stocked	•	•				14	504
	TS35	3093205	TS35C	3546686		63.5	Stocked	•	•		•		12	432
	TS36	3117461	TS36C	4065520		63.5	Stocked	•	•		•		12	432
	TS37	3117523	TS37C	4065521		63.5	Stocked	•	•	•	•	•	12	432
	TS39	3750831	TS39C	370830		63.5	Stocked	•	•		•	•	14	504
	TS40	4004717	TS40C	4004682		63.5	Stocked	•	•	•	•	•	15	540
TS41	4004714	TS41C	4004713		63.5	Stocked	•	•	•	•	•	15	540	
C Series	C4	1010761				38	Stocked	•	•	•			15	750
	C4-1	1010776				38	Stocked	•	•				15	750
	C6	1010740				48	Stocked	•	•				15	750
	C7	1010742				48	Stocked	•	•	•			15	750

Tool Recommendation:

Gold (best)
 Silver (better)
 Bronze (good)

Kennametal

The proven global leader in the design, manufacture, implementation, and sale of premium-quality tooling systems for underground and surface mining, road rehabilitation, aggregates production, and waste recycling!

United States / Canada / Mexico

Phone: 800.458.3608
Fax: 800.521.3319
mcs-na.service@kennametal.com

Germany / European Served Area

Phone: (49) 6172 737 498
Fax: (49) 6172 737 42 453
mcs-ag.service@kennametal.com

Poland / Slovakia / Baltics

Phone: (48) 32 42 15 888
Phone: (48) 32 42 15 405
Fax: (48) 32 47 89 112

Brazil / Latin America

Phone: (55) 19 3936 9200
Fax: (55) 19 3936 9201

Argentina

Phone: (54) 011 4719 0700
Fax: (54) 011 4719 6116

Chile

Phone: (56) 2 2641177
Fax: (001) 888 442 4964

China

Phone: (86) 400 6501 388
Fax: (86) 10 8561 5263

Japan

Phone: (81) 3 3820 2855
Fax: (81) 3 3820 2800

Korea

Phone: (82) 2 2109 6967
Fax: (82) 2 2109 6981

Thailand / Singapore / Vietnam / Philippines

Phone: (66) 2642 3455
Phone: (66) 2246 8025 – 32
Fax: (66) 2641 2736 – 8

Malaysia / Indonesia

Phone: (6) 03 5569 9080
Fax: (6) 03 5569 0080

India

Phone: (91) 80 2839 4321
Phone: (91) 80 2219 8444
Fax: (91) 80 2839 1300
bangalore.information@kennametal.com

Australia / New Zealand

Phone: (61) 7 3801 5844
Fax: (61) 7 3801 5826
sydney.service@kennametal.com

South Africa / Sub Saharan Area

Phone: (27) 11397 3540
Fax: (27) 11397 3222



Edm. Vandervaerenstraat, 60 A
B - 1560 HOEILAART
☎ 32(0)2 657 61 77
☎ 32(0)2 657 54 58
e-mail: info@geotechno.be
www.geotechno.be